

**Installation Instructions**

**THIS EQUIPMENT MUST ONLY BE INSTALLED AND MAINTAINED BY A SUITABLY SKILLED AND TECHNICALLY COMPETENT PERSON. THIS EQUIPMENT IS A PIECE OF CLASS 1 EQUIPMENT AND MUST BE EARTHED. DO NOT CHANGE ANY PANEL CONNECTIONS WITH THE PANEL'S POWER APPLIED (MAINS OR BATTERY POWER).**

**INSTALLATION PROCEDURE**

All cables must be installed in accordance with all applicable national, regional or local standards. In the UK this is BS 7671 IEE Wiring Regulations and BS 5839-1, Fire detection and alarm systems for buildings: Code of practice for system design, installation and maintenance. Fire resistant, screened cable should be used throughout the installation and Mains wiring should be segregated from extra low voltage field wiring.

For PERMANENTLY CONNECTED equipment, a readily accessible disconnect device shall be incorporated external to the equipment.

The general requirement for the Mains supply to the panel is fixed wiring, using 3 core cable, (no less than 1mm<sup>2</sup> and no more than 2.5mm<sup>2</sup>), or a suitable three conductor system fed from an isolating switched fused spur, fused at 3A. The Mains supply must be exclusive to the panel.

HINT. As an alternative to a switched fused spur, a double pole isolating device (B) may be used in the Mains feed from the Main Distribution Board (A) to the panel (C), providing it meets the appropriate wiring regulations – see Fig 1.

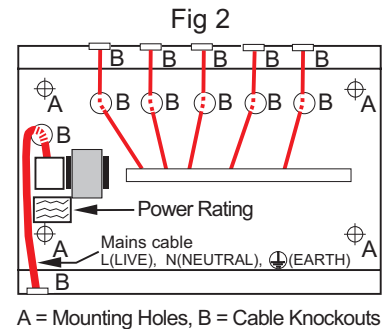
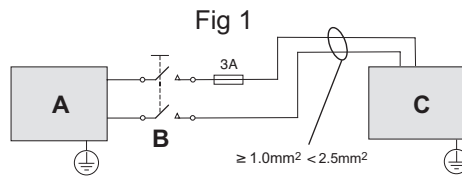

- Remove the panel's lid (disconnect attached loom connector).
- Fit the panel's back box securely to a wall using the mounting holes provided and suitable screw fixings. Remove required number of knockouts and fill holes with good quality cable glands – see Fig 2.

CAUTION: DO NOT use an insulation tester (Megger) with any electronic devices connected as the test voltage will totally destroy the devices.

- Test field cables and ensure they are fault-free, i.e. check continuity of cable runs (including screens).
- Connect external Mains cable to the panel's fused Mains terminal block (with Mains isolated) – see Fig 2.

CAUTION: RISK OF EXPLOSION IF BATTERY IS REPLACED BY AN INCORRECT TYPE. DISPOSE OF USED BATTERIES ACCORDING TO THE INSTRUCTIONS.

- Also, if the battery leads are connected in reverse, the battery fuse (F1) will blow which may damage the panel and invalidate the warranty.
- Position and connect the panel's two internal 12V sealed lead acid batteries (with battery supply isolated) – see Fig 3 & Fig 4.
- Connect zone circuits to the panel – see Fig 5.
- Connect sounder circuits to the panel – see Fig 5.
- Connect ancillary connections to the panel.
- Refit the panel's lid (re-connect loom connector).
- Apply Mains and battery supply to power up the panel.
- The panel should be in normal mode. If not, investigate and rectify any faults indicated on the panel.
- Finally, test the panel – see pages 2 & 3.

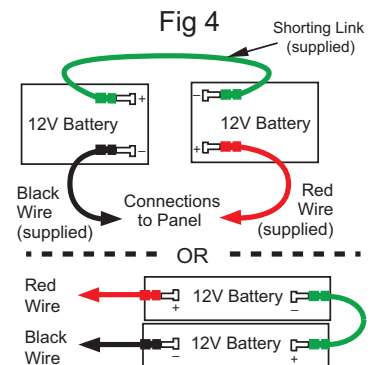
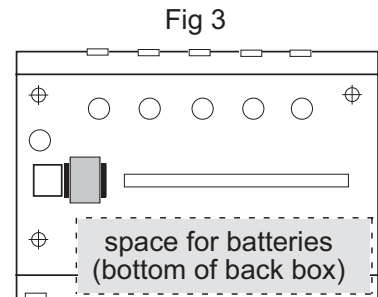

TYPICAL ZONE CIRCUIT - Call points wired before detectors  
- Detector base diodes not needed.

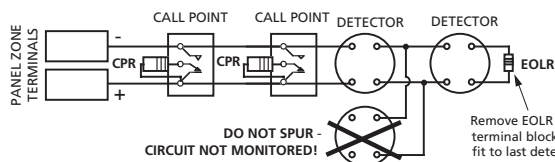

TYPICAL ZONE CIRCUIT - With mixed order call points and detectors  
- Detector bases fitted with continuity diodes and negative connection linked out.

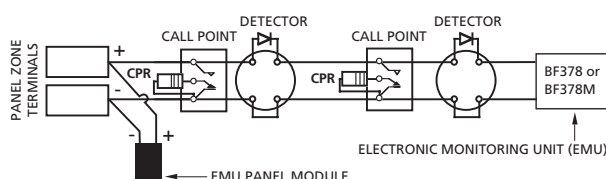
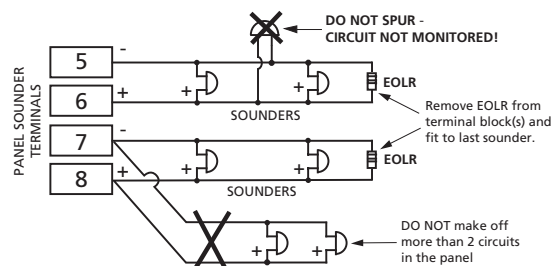

Fig 5

TYPICAL SOUNDER CIRCUITS  
Only use polarised sounders!



EOLR = End of Line Resistor (6k8Ω, 0.25W) - supplied  
CPR = Call Point Resistor (470 - 680Ω, 0.5W) - supplied with call point

## TESTING THE PANEL

When testing the panel with the panel lid open, always isolate the Mains and disconnect the batteries. The panel can be tested before connecting field wiring. If testing before installation, ensure the end-of-line resistors are fitted in the panel's sounder and detector terminal blocks.

Position and connect two suitable 12V batteries in the panel as shown in Fig 3 and Fig 4 (page 1). When the batteries are connected, the POWER SUPPLY FAULT indicator will light and the warning beeper will sound. Connect the Mains wiring and turn the Mains supply on. The MAINS ON indicator will light, the POWER SUPPLY FAULT indicator will go out and the warning beeper will silence (providing the batteries are not flat).

### WITH THE KEYSWITCH AT NORMAL POSITION

The MAINS ON indicator is lit. No other indicators are lit. No sounders are active. The pushbuttons are inoperative.

### TURN THE KEYSWITCH TO ARM CONTROLS POSITION

**Note:** None of the panel's pushbuttons are operative unless the keyswitch is in the ARM CONTROLS position. Press RESET/RESOUND/TEST ZONE LAMPS. The ZONE FIRE and ZONE FAULT indicators light and the warning beeper will sound. The MAINS ON indicator will remain lit. All the other indicators will NOT light. Release the pushbutton and the panel will return to normal.

### TEST THE POWER SUPPLY MONITORING CIRCUIT

Switch off the Mains. The POWER SUPPLY FAULT indicator will light, the MAINS ON indicator will extinguish, and the warning beeper will sound. Press SILENCE FAULT SOUNDERS and the warning beeper will silence but the POWER SUPPLY FAULT indicator will remain lit. Reconnect the Mains and the panel will revert to normal. Disconnect the battery. The POWER SUPPLY FAULT indicator will light and the warning beeper will sound. Reconnect the battery and after a short time the panel will revert to normal (i.e. only the MAINS ON indicator light on). Note: This test should be carried out with a set of new and fully charged batteries – deteriorated cells will show a fault even when connected and charged up.

### TEST THE SOUNDER MONITORING CIRCUITS

**DO NOT** carry out this test with the ZONE FIRE indicators lit as sounder fuses F2 & F3 could blow. Ensure the end-of-line resistor is connected across each of the sounder circuits on terminals 5 & 6, 7 & 8. Short the sounder terminals 5 & 6. The SOUNDER FAULT indicator will light and the warning beeper will sound. Press SILENCE FAULT SOUNDERS and the warning beeper will silence but the SOUNDER FAULT indicator will stay on. Remove the short and the panel will revert to normal. Open circuit the sounder terminals 5 & 6 by disconnecting one leg of the end-of-line resistor. The SOUNDER FAULT indicator will light and the warning beeper will sound. Press SILENCE FAULT SOUNDERS and the warning beeper will silence but the SOUNDER FAULT indicator will stay on. Remake the circuit and the panel will revert to normal. Repeat the test for the other sounder circuit via terminals 7 & 8.

### TEST THE DETECTOR MONITORING CIRCUITS

Make sure an end-of-line device (EOLD) is connected across each pair of detector terminals (9 & 10, 11 & 12, etc.). The EOLD would either be a 6.8k $\Omega$  resistor or Electronic Monitoring Unit (EMU) and associated Panel Module, depending on the installation. Refer to Fig 5 (page 1) & EMU instructions for connections.

The following four conditions can exist on the detector monitoring circuits:

- 1. Normal Condition:** Current flows round the detector loop via the EOLD to monitor the wiring.
- 2. Open Circuit Fault:** The wiring is broken at some point and the monitoring current cannot flow through the EOLD.
- 3. Short Circuit Fault:** A short circuit exists at some point and too much monitoring current flows.
- 4. Fire Condition:** A partial short exists and the monitoring current increases but not enough to show a short circuit fault. Most smoke detectors make a partial short when they are triggered but manual call points and other normally open switches need to have 470 or 680 $\Omega$  resistors connected in series in order to give a partial short. (Check - Resistor may be built into the Call Point - see Fig 5, page 1.)

### OPEN CIRCUIT FAULT TEST

Open circuit the zone circuit terminals (9 & 10) by disconnecting one wire of the EOLD. The ZONE 1 FAULT indicator and internal ZONE 1 OPEN CIRCUIT FAULT indicator will light. The warning beeper will also sound. Press SILENCE FAULT SOUNDERS and the warning beeper will silence but the indicators will stay on. Reconnect the EOLD and the panel will revert to normal.

### SHORT CIRCUIT FAULT TEST

Short circuit the zone circuit terminals (9 & 10). The ZONE 1 FAULT indicator and internal ZONE 1 SHORT CIRCUIT FAULT indicator will light. The warning beeper will also sound. Press SILENCE FAULT SOUNDERS and the warning beeper will silence but the indicators will stay on. Remove the short and the panel will revert to normal. Repeat the test for the other zone circuit via terminals 11 & 12.

### FIRE CONDITION

Simulate a Fire condition by connecting and activating a Call Point, or by fitting a 470 to 680 $\Omega$  resistor across terminals 9 & 10. The sounder output relay will operate. The ZONE 1 FIRE indicator lights and warning beeper sounds. Press SILENCE ALARM SOUNDERS. The sounder outputs return to normal but the ZONE 1 FIRE indicator will still be lit and the warning beeper will still sound. Press RESET/RESOUND/TEST ZONE LAMPS and the panel will go back into alarm as the Fire condition is still present. Remove the Fire condition. Press SILENCE ALARM SOUNDERS, then RESET/RESOUND/TEST ZONE LAMPS, and the panel reverts to normal. Repeat the test for the other zone terminals.

## Notes:

- 1) Pressing RESET/RESOUND/TEST ZONE LAMPS when in the unsilenced Fire condition (i.e. Sounder Outputs energised) has no effect. The sounders MUST be Silenced first before Reset is active.
- 2) When the Alarm Sounders are silenced, the warning beeper will sound and cannot be silenced.
- 3) Resetting the system from the Silenced Fire state with the fire condition still existing will retrigger the alarm.

## EVACUATE

Press EVACUATE. The Sounder Outputs will operate, the ZONE FIRE indicators will light and the warning beeper will sound. Press SILENCE ALARM SOUNDERS and the Sounder Outputs will return to the normal state. The ZONE FIRE indicators will still be lit and the warning beeper will still be active. Press RESET/RESOUND/TEST ZONE LAMPS to return the panel to normal state.

## TESTING THE SYSTEM

Check each detector and sounder on the system, and check the functions of the panel. Check all circuits for open and short circuit faults. If continuity diodes are fitted remove each head in turn and check that call points are still operative. When testing is complete return the keyswitch to NORMAL position.

## ANCILLARY FACILITIES (Links and internal features are shown in Fig 6 below)

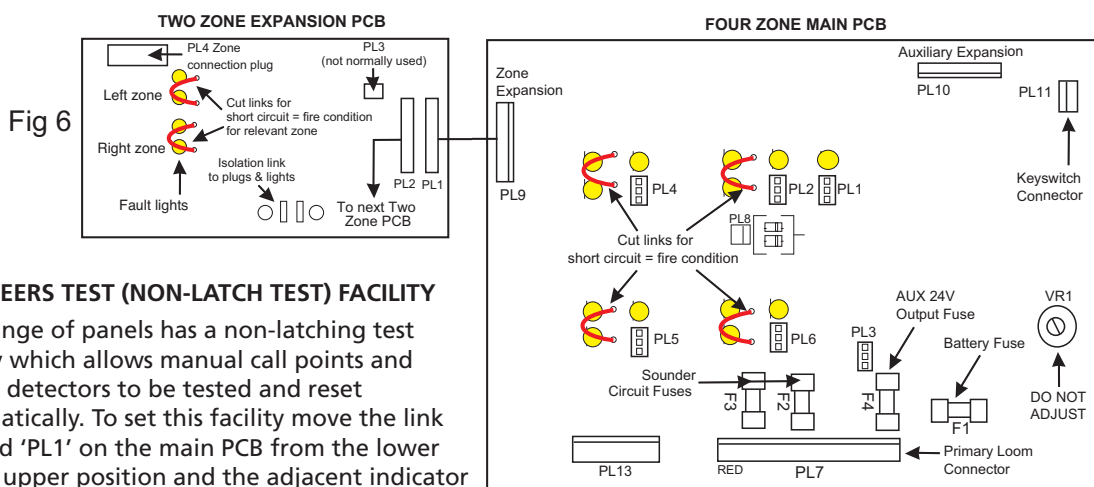

## ENGINEERS TEST (NON-LATCH TEST) FACILITY

This range of panels has a non-latching test facility which allows manual call points and smoke detectors to be tested and reset automatically. To set this facility move the link marked 'PL1' on the main PCB from the lower to the upper position and the adjacent indicator will light, the warning beeper will sound and cannot be silenced. When an alarm condition is caused the alarm sounders will operate for about half a second and will silence for three seconds before resounding. This will continue until the cause of the alarm is removed by the smoke clearing from a detector or the call point being reset. When testing is complete, replace the link to the lower position.

## ZONE ISOLATION FACILITY

Each Detector Zone can be isolated individually by moving the links (PL2/PL4/PL5/PL6) from the lower to the upper position. The adjacent indicator and relevant ZONE FAULT indicator will light to show that the zone is isolated. The warning buzzer will sound and cannot be silenced. When testing is complete, replace the link to the lower position.

## TO REVERT TO SHORT CIRCUIT = FIRE

This facility overrides the short circuit fault monitoring for each zone and allows the panel to be used on installations which do not have Call Point Resistors fitted. It produces a short circuit Fire condition when activated. To enable this facility cut the wire links (LK1/LK2/LK3/LK4) on the main PCB.

## AUXILIARY EXPANSION PLUG (PL10)

This plug connector offers facilities for driving Repeater Panels, Fire and Fault relays and a "Class Change" input. These facilities require various ancillary devices to be added to the panel (not included).

## AUX 24V +VE

This output is a regulated, unmonitored, output fused at 1A (F4), available from terminal 1 in the panel's base connections. With link 'PL3' on the main PCB linked in position furthest from the F4 fuse this output is continuous. If linked nearest to the F4 fuse then the output is present when the panel is normal but is switched off when the relay is activated. This facility can be used to provide a fail-safe output via AUX 24V, that "switches off" when the sounders are activated, or if power to the panel fails.

**Note:** Any load provided by this output increases the quiescent drain on the panel's supply which in turn affects the stand-by time of the system. It is not intended to supply door release systems.

## VOLTAGE FREE RELAY CONTACTS

These single pole relay outputs, available via terminals 2 (normally closed), 3 (common), and 4 (normally open) in the panel's base connections, change over when the sounders are activated. They must not be used to switch Mains potentials, the contacts being rated at 30Vdc and 1.0A.

# FP8E TECHNICAL SPECIFICATION

## CONTROLS

EXTERNAL PUSHBUTTONS (KEYSWITCH ACTIVATED)

- RESET / RESOUND / TEST ZONE LAMPS
- SILENCE ALARM SOUNDERS ■ EVACUATE
- SILENCE FAULT SOUNDERS

INTERNAL

- Engineer Detector Test
- Zone Isolate
- Revert to short circuit = fire (no resistors in Call Points).

## EXTERNAL INDICATORS

- SOUNDER FAULT ■ POWER SUPPLY FAULT
- MAINS ON ■ ZONE FIRE ■ ZONE FAULT

## INTERNAL INDICATORS

- OPEN CIRCUIT ZONE FAULT ■ SHORT CIRCUIT ZONE FAULT
- ZONE ISOLATED ■ ENGINEER TEST SELECTED

## OUTPUTS

- 2 sounder circuits (Alarm relay contacts can be obtained by connecting an RLP-24 relay to a sounder circuit).
- Ancillary connections for expansion modules will allow the following: (1) Repeater Panels; (2) Multiple sounder outputs; (3) Connection to Landlord's Panel.

|   |           |               | FP8E (1.4A SUPPLY)   |               |        |
|---|-----------|---------------|--|---------------|--------|
|   |           |               | Part No. FF388-3   |               |        |
| <b>POWER SPECIFICATION</b>                                      |           |               |  |               |        |
| MAINS SUPPLY VOLTAGE  | FREQUENCY | RATED CURRENT | 220 - 230 V a.c.   | 50 Hz / 60 Hz | 330 mA |
| INTERNAL POWER SUPPLY   |           |               | 27 V d.c. nominal  |               |        |
| TOTAL OUTPUT CURRENT LIMITED TO                                 |           |               | 1400 mA  |               |        |
| AUXILIARY POWER OUTPUT  |           |               | 27 V d.c. nominal  |               |        |
| MAINS SUPPLY MONITORED FOR FAILURE                              |           |               | YES  |               |        |
| BATTERY CHARGER MONITORED FOR FAILURE                           |           |               | YES  |               |        |
| LEAD ACID BATTERIES MONITORED FOR DISCONNECTION / FAILURE       |           |               | YES  |               |        |
| <b>DETECTOR CIRCUIT SPECIFICATION</b>                           |           |               |  |               |        |
| NUMBER OF CIRCUITS  |           |               | 8  |               |        |
| LINE FAULT MONITORED FOR OPEN CIRCUIT                           |           |               | YES  |               |        |
| LINE FAULT MONITORED FOR SHORT CIRCUIT                          |           |               | YES (can be disabled)  |               |        |
| LINE FAULT MONITORED FOR DETECTOR REMOVAL                       |           |               | Yes, if End of Line Monitoring Unit fitted in place of End of Line Resistor  |               |        |
| END OF LINE RESISTOR (SUPPLIED)                                 |           |               | 6800 Ω, 5% tolerance, 0.25 W (colour code - blue, grey, red, gold)   |               |        |
| DETECTOR CONTINUITY DIODES                                      |           |               | Silicon 1N4001 or Schottky type (required if End of Line Monitoring Unit fitted)   |               |        |
| CALL POINT RESISTOR (NOT SUPPLIED)                              |           |               | 470 to 680 Ω, 0.25 or 0.5 W  |               |        |
| MAXIMUM NUMBER OF SMOKE/HEAT DETECTORS PER ZONE                 |           |               | 20 (maximum detector current = 2 mA)   |               |        |
| MAXIMUM NUMBER OF MANUAL CALL POINTS PER ZONE                   |           |               | No limit   |               |        |
| <b>SOUNDER CIRCUIT SPECIFICATION</b>                            |           |               |  |               |        |
| NUMBER OF CIRCUITS  |           |               | 2  |               |        |
| END OF LINE RESISTOR (SUPPLIED)                                 |           |               | 6800 Ω, 5% tolerance, 0.25 W (colour code - blue, grey, red, gold)   |               |        |
| LINE FAULT MONITORED FOR OPEN CIRCUIT                           |           |               | YES  |               |        |
| LINE FAULT MONITORED FOR SHORT CIRCUIT                          |           |               | YES  |               |        |
| OUTPUTS FUSED AT  |           |               | 1 A  |               |        |
| MAXIMUM TOTAL OUTPUT CURRENT (ALL OUTPUTS)                      |           |               | 1400 mA  |               |        |
| MAXIMUM NO. OF BELLS @ 25 mA EACH                               |           |               | 56   |               |        |
| MAXIMUM NO. OF ELECTRONIC SOUNDERS @ 20 mA EACH                 |           |               | 70   |               |        |
| AUXILIARY RELAY CONTACTS (DO NOT CONNECT MAINS VOLTAGES)        |           |               | 1A 30 V d.c. max. Voltage-Free   |               |        |
| <b>FUSES - ALL FUSES COMPLIANT TO IEC (EN 60127 PT2)</b>        |           |               |  |               |        |
| MAINS TERMINAL BLOCK  |           |               | 400 mA T 20 mm   |               |        |
| SOUNDER OUTPUTS (F2, F3)  |           |               | 1 A F 20 mm  |               |        |
| BATTERY FUSE (F1)   |           |               | 1.6 A F 20 mm  |               |        |
| AUXILIARY OUTPUT (F4)   |           |               | 1 A F 20 mm  |               |        |
| DOOR RETAINING MAGNETS  |           |               | <b>DO NOT USE PANEL POWER SUPPLY AS YOU WILL DRASTICALLY REDUCE BATTERY STAND-BY TIME.</b>   |               |        |
| <b>CONNECTION BLOCK</b>   |           |               |  |               |        |
| LARGEST ACCEPTABLE CONDUCTOR SIZE                               |           |               | 2.5 mm <sup>2</sup>  |               |        |
| SMALLEST ACCEPTABLE CONDUCTOR SIZE                              |           |               | 0.75 mm <sup>2</sup>   |               |        |
| <b>PHYSICAL</b>   |           |               |  |               |        |
| ENCLOSURE (WIDTH x HEIGHT x DEPTH)                              |           |               | 405 x 267 x 92 mm  |               |        |
| WEIGHT (WITHOUT BATTERIES)                                      |           |               | 5 Kg   |               |        |
| IP RATING (to EN 60529)   |           |               | IP30 (when correctly installed)  |               |        |
| <b>ANCILLARIES</b> (Individual datasheets available on request) |           |               |  |               |        |
| REPEATER PANEL (available in 10 and 20 zone versions)           |           |               | Up to three Repeaters per control panel. Wiring = five cores plus one per zone. Maximum cable length = 200 metres. Facilities = Common fault light; one fire light per zone; warning buzzer; test button (test lights, buzzer & interconnecting wiring). |               |        |
| 4 ZONE MONITORED SOUNDER EXTENDER KITS                          |           |               | Connects to existing sounder circuits to provide four additional monitored sounder circuits.   |               |        |
| RLP-24 5A RELAY ON PLATE (Fits single gang back boxes)          |           |               | General purpose polarised and suppressed relay for use with 24 volt fire alarm systems. Can switch Mains loads.  |               |        |
| FLUSH BEZEL   |           |               | Order Code: FF385  |               |        |
| <b>ENVIRONMENTAL</b>  |           |               |  |               |        |
| OPERATING TEMPERATURE   |           |               | -10°C to +40°C   |               |        |
| HUMIDITY  |           |               | 5% to 95% RH (non-condensing)  |               |        |

## QUIESCENT CURRENT / BATTERY STAND-BY TIME (HRS)

|                                      |     |
|--------------------------------------|-----|
| NUMBER OF ZONES                      | 8   |
| QUIESCENT CURRENT (mA)               | 70  |
| MAX. LOAD CURRENT (A)                | 1.4 |
| STAND-BY TIME (HRS) 2.6 Ah BATTERIES | 27  |
| STAND-BY TIME (HRS) 4.0 Ah BATTERIES | 47  |
| STAND-BY TIME (HRS) 6.0 Ah BATTERIES | 75  |

The quiescent currents listed are for the following conditions - Mains Supply failed, detector and sounder End of Line resistors fitted, no other loads supplied by the panel. The battery stand-by times are guidelines only based on the above conditions and a full sounder load for 30 minutes. Additional loads that increase the quiescent current in the normal alarm state and sounder loads must be considered when calculating stand-by time. Batteries in poor condition greatly reduce stand-by time.

E&OE. No responsibility can be accepted by the manufacturer or distributors of this equipment for any misinterpretation of this instruction, or for the compliance of the system as a whole. The manufacturers policy is one of continuous improvement and we reserve the right to make changes to product specifications at our discretion and without prior notice.